

MI-93 Infrared Motion Sensor Instruction

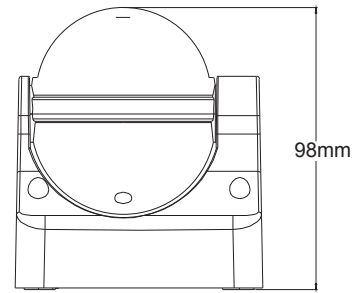
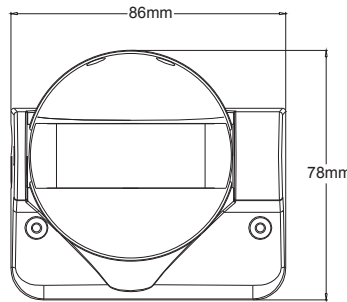

Summary

This product is a new type of energy-saving lighting switch, it adopts high sensitivity detector, integrate circuit and SMT;It gathers automatic, convenient, safe,energy-saving, practical functions; It has wide detection range made up of up and down, left and right service field; It utilizes human motion infrared rays as control signal sources,when one enters the detection field, it will start the controlled load at once; It can identify day and night automatically; It is easy to install and its usage is wide; It has the function of power indication and detection indication.

Specifications

Power source: 110-130V/AC
220-240V/AC

Power frequency:50/60Hz

Rated load: 1200W Max.tungsten (220-240V/AC)
200W Max.fluorescent (220-240V/AC)
800W Max.tungsten (110-130V/AC)

Time setting: min: 8sec±3sec max:7min±2min

Light-control:<3LUX~daylight (adjustable)

Detection range: 12m Max(<24°C)

Detection angle: 180° 140°

Working temperature:-10°C~+40°C

Working humidity: <93%RH

Installation height: 0.5m~3.5m

Detection motion speed:0.6-1.5m/s

Power consumption:0.45W (static 0.1W)

Function

- Detection field: The wide detection range is made up of up and down, left and right(see the following diagram), the detection range could be adjusted according to your desire, but the moving orientation in detection field has great relation with the sensitivity;
- Identify day and night automatically: The light-control of MI-93 could be adjusted according to your desire: when turn to SUN (max), it will work day and night, when turn it to MOON (min), it will only work in the light-control less than 3LUX. As for adjustment, please refer to testing way;
- Time setting is added continually: When it receives the second induction signals after the first induction, it will compute time once more on the rest of the first time setting basis (set time);
- Time setting is adjustable: It can be set according to your desire, the minimum is 8s±3s,the maximum is 7min±2min.

Sensor information

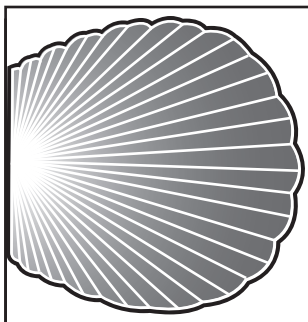

12m

Correct moving orientation

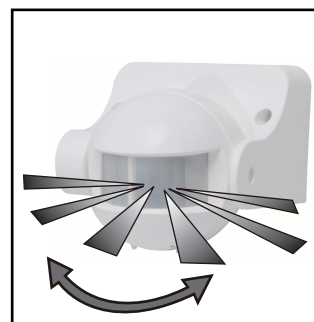

180°/140°

Detection angle

Connection-wire diagram

1 red
2 blue
3 brown
4 earthing
connect 2 and 3 with power;
connect 2 and 1 with load.
NOTE: The fuse in the figure is 6.3A and
it should have VDE certification!

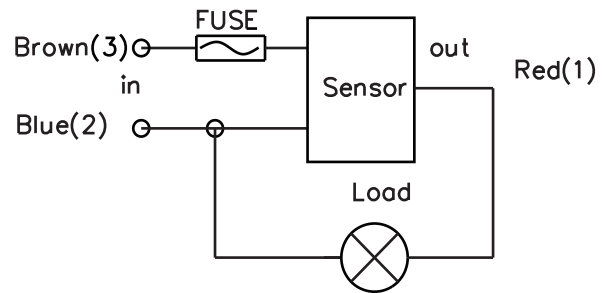

Installation

1. Shut off power;
2. Loosen the screw on the bottom lid, open the wiring hole, pass the wire of power and load through the bottom lid;
3. Fix the bottom lid with inflated screw on the selected position;
4. Connect the power and load wire into connection-wire column according to the connection-wire diagram;
5. Put the sensor on the bottom lid, twist the screw tightly then electrify it and test it.

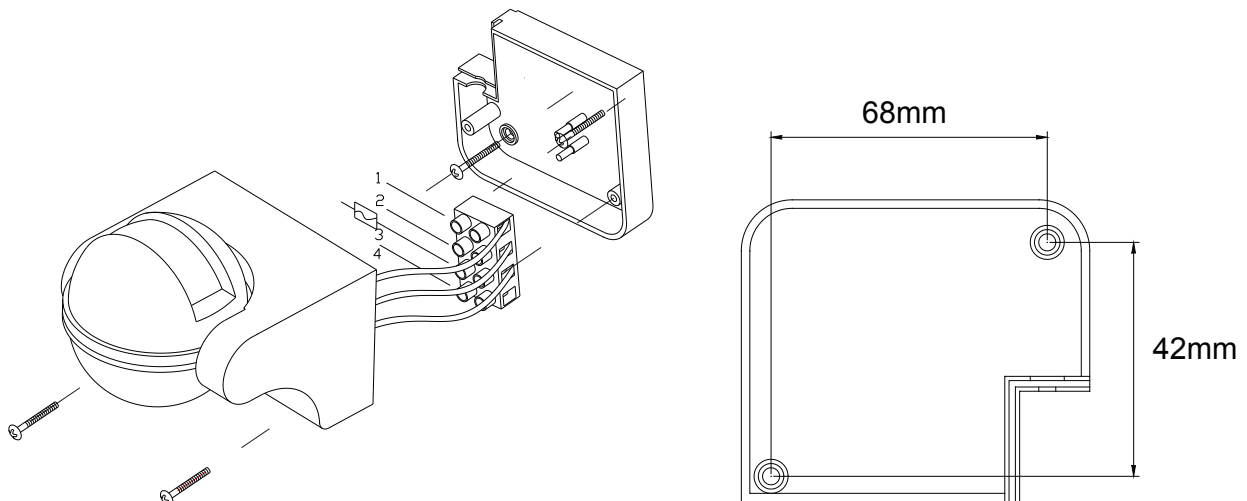

Test

- Turn the light-control knob clockwise to the maximum (SUN), turn time knob anti-clockwise to the minimum;
- Switch on power, the controlled load should not work, under the no induction signal condition, the load should stop work within 5-30sec;
- Make it sense again 5-10sec later since the first is out, the load should work, the load should stop working within 5-20sec;
- Turn LUX knob to minimum anti-clockwise, if you test it when the light-control is more than 3LUX, the induction load would not work after the load stops working; the load should work if you cover the detection window with opaque object (towel etc), it would be regular the load stops to work within 5-15sec under no induction signal condition.

Note

- Should be installed by electrician or experienced person;
- Avoid installing it on the unrest object;
- There should be no hindrance and moving objects in front of the detection windows to effect detection;
- Avoid installing it near air temperature alteration zones such as air condition, central heating, etc;
- Considering your safety, please do not open the cover when you find the hitch after installation;
- If there is difference between instruction and the function the product has, please give priority to product and sorry not to inform you additionally.

Some problem and solved way

- 1、 The load do not work:
 - a: Please check if the connection-wiring of power and load is correct;
 - b: Please check if the load is good ;
 - c: Please check if the working light set correspond to light-control.
- 2、 The sensitivity is poor:
 - a: Please check if there has hinder in front of the detection window to effect to receive the signal;
 - b: Please check if the ambient temperature is too high;
 - c: Please check if the induction signal source is in the detection fields;
 - d: Please check if the installation height corresponds to the height showed in the instruction;
 - e: Please check if the moving orientation is correct.
- 3、 The sensor can not shut off the load automatically:
 - a: Please check if there is continual signal in the detection field;
 - b: Please check if the time setting is the longest;
 - c: Please check if the power correspond to the instruction;
 - d: Please check if the temperature near the sensor change obviously, such as air condition or central heating etc.