

MI- 83 Infrared Motion Sensor Instruction

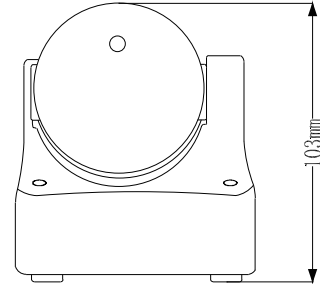
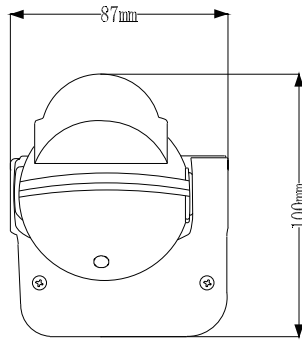

Summary

The product is a new saving-energy switch adopting the good sensitivity detector, integrated circuit and SMT. It gathers automatic, convenient, safe, saving-energy and practical functions. The wide detection field is made up of up and down, left and right service field. It works by receiving human motion infrared rays. When one enters the detection fields, it can start the load at once and identify day and night automatically; Its installation is very convenient and its using is very wide. It has the functions of the power indication and the detection indication.

Specifications

Power source: 100-130V/AC
220-240V/AC

Power frequency: 50/60Hz

Rated load: 800W Max.tungsten(100-130V/AC)
150W Max.fluorescent(100-130V/AC)
1200W Max.tungsten(220-240V/AC)
300W Max.fluorescent(220-240V/AC)

Light-control: <3LUX~2000LUX (adjustable)

Time setting: Min 8sec±3sec

Max7min±2min (adjustable)

Detection angle: 180° 140° 110°

Detection range: 12m Max(<24°C)

Working temperature: -10~+40°C

Detection motion speed: 0.6~1.5m/s

Working humidity: <93%RH

Installation height: 0.5m~3.5m

Power consumption: 0.45W(static 0.1W)

Sensor information

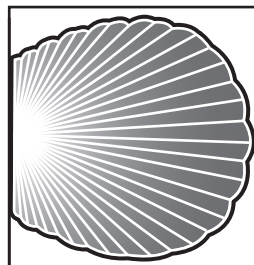
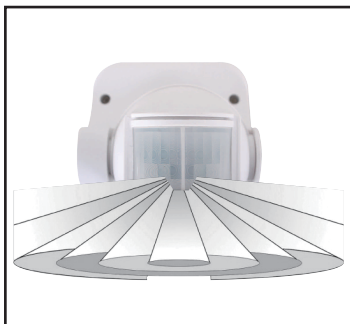

12m

Correct moving orientation

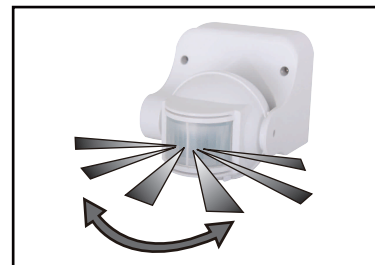

110°/ 140°/ 180°
Detection angle

Function

- Detection field: the detection field (see the following diagram) is made up of up and down, left and right service field, it can be selected according to the consumer's desire. But the moving orientation has great relationship with the sensitivity.

- Can identify day and night: The consumer can adjust light-control when MI-83 works. It can work at night and in the daytime when it is adjusted on the “sun” position (max). It can work in the light-control less than 3LUX when it is adjusted on the “moon” position (min). As for the adjustment pattern, please refer to the testing pattern.
- Power and detection indication: The indicator lamp can flash one time every 4sec after switching on the power. It can flash 2 times every 1sec after it receives the signals. At the same time, it can show if the sensor is normal for the detection and the power.
- Time setting is added continually: When it receives the second induction signals after the first inductor, it can compute time once more on the rest of the first time setting basic. (Set time).
- Time setting is adjustable: It can be set according to the consumer’s desire. The minimum time is $8\text{sec} \pm 3\text{sec}$. The maximum is $7\text{min} \pm 2\text{min}$.

Installation (see the following diagram)

- Switch off the power.
- Screw off the nail on the bottom. Open the wire hole. The power wire and the load wire are bored in the bottom.
- Fix the bottom on the selected position with the inflated screw.
- Connect the power and the load into the connection-wire column according to the sketch diagram.
- Fix the sensor on the bottom, please screw on the nail and switch on the power. Then you can test it.

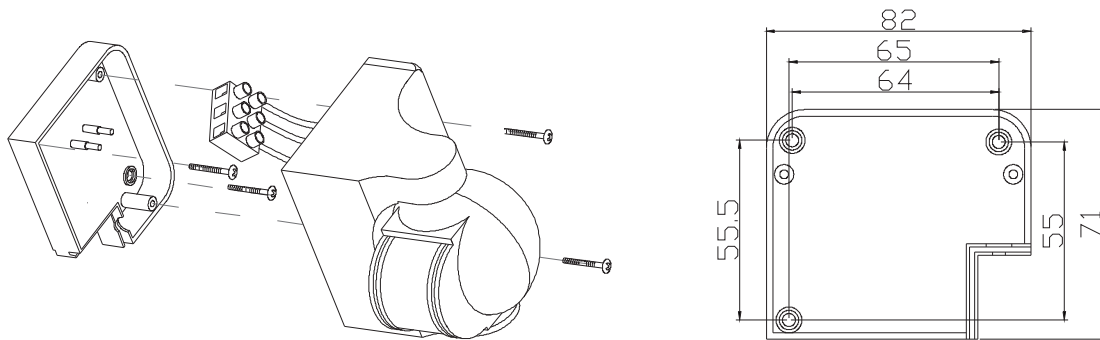

Connection-wire diagram

(see the right diagram)

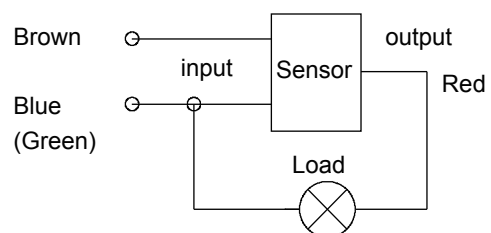

Test

- Turn the light-control knob clockwise on the maximum (sun), turn the time knob clockwise on the minimum.
- When you switch on the power, the load doesn't work and the indicator lamp flashes once every 4sec. After 5~10sec, the load works and the indicator lamp flashes twice every 1sec. Under the conditions of no inductor signals, the load should stop working within 5~30sec, the indicator lamp should still flash once every 4sec.

- After the first is out, make it sense again after 5~10sec. The load should work and the indication flash speed is two times in 1sec. The load should stop working within 5~15sec.
- Turn light control knob anti-clockwise on the minimum. If it is adjusted in the less than 3LUX, the inductor load should not work after load stop working. If you cover the detection window with the opaque objects (towel etc), the load work .under the conditions of no inductor signals, the load should stop working within 5~15sec.

Notes

- Electrician or experienced human can install it.
- The unrest objects can't be regarded the installation basis-face.
- In front of the detection window there should be no hinder or unrest objects effecting detection.
- Avoid installing it near air temperature alteration zones for example: air condition, central heating, etc.
- Please don't open the case for your safety if you find the hitch after installation.

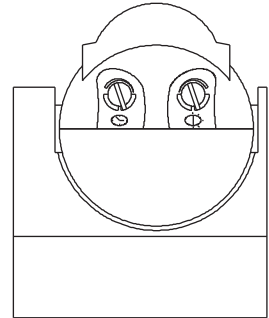

Some problem and solved way

- **The load don't work:**
 - a: Check the power and the load.
 - b: If the load is good.
 - c: If the indicator lamp speed quicken after sensing.
 - d: Please check if the working light correspond to the ambient light.
- **The sensitivity is poor:**
 - a: Please check if in front of the detection window there is hinder that effect to receive the signals.
 - b: Please check if the ambient temperature is too high.
 - c: Please check if the signals source is in the detection fields.
 - d: Please check the installation height.
 - e: If the moving orientation is right.
- **The sensor can't shut automatically the load:**
 - a: If there is continual signal in the detection fields.
 - b: If the time delay is set to the longest.
 - c: If the power correspond to the instruction.
 - d: If the air temperature change near the sensor, for example air condition or central heating etc.

! **Warning!**

- **Please confirm with professional installation.**
- **Please cut off power supply before installation and removal operations.**
- **Make sure that you have cut off the power for safety purposes.**
- **Improper operation caused losses, the manufacturer does not undertake any responsibility.**

We are committed to promoting the product quality and reliability, however, all the electronic components have certain probabilities to become ineffective, which will cause some troubles. When designing, we have paid attention to redundant designs and adopted safety quota to avoid any troubles.

This instruction, without our permission, should not be copied for any other purposes.